

INSTRUCTIONS FOR INSTALLING THE R K P SEED TUBE GUARD

When working on your planter in the raised position be certain that service locks are installed or parking stands are down and properly secured. Wear proper protective clothing and eye protection. Review the safety section in your operators manual.

IMPORTANT: READ INSTRUCTIONS CAREFULLY (Read Notes at Bottom of Page First)

1. If seed tube guides (A) are not preassembled attach them to support bracket © with two 5/16" x 1/2" bolts and nuts.
2. If the 5/16" holes at the bottom of the shank are badly worn 3/8" bolts and rivets are available. Enlarge holes to 3/8" (no larger). Be careful not to reduce the material from the holes to the sheet metal edge more than necessary.

White planters do not have a wear problem with these mounting holes. The original roll pins can be reused in place of the provided capscrew and rivet.

3. Insert bushings (B) into holes in bracket (C). Insert bracket with bushings between sheet metal sides of shank assembly (D).

Insert 7/8" long bolt (E) through shank assembly and rear bushing. Insert semi tubular rivet (F). If front bushing is not clamped tight use a C-clamp or vise grips. Install nut (G) and tighten.

4. Hold a hammer against the head of rivet (F). Using a lighter hammer clinch the tubular end of the rivet. It must be clinched very tight. Approximately 3/32" of clinching material should remain.

5. Install opener disks (H) using the correct number of shims (I) to minimize the clearance between the wear plates and the disks. This will reduce the amount of disk deflection when ground loads are applied. The disks will probably rub the wear plates at some point when you roll them by hand. The resulting resistance must be minimal. We do not recommend shimming the disks by measuring the length of contact between the disks. It should not be detrimental however if you prefer to set them that way. On some shanks (especially XP), the number of shims will be determined by the clearance between the top of opener disks and the shank.

6. If your planter is equipped with outside disk scrapers be sure they do not prevent the disks from turning freely. Scrapers can usually be eliminated if the gauge wheel arm pivots are repaired so that the tires can be held against the disks. The RKP gauge wheel arm pivot kit will accomplish this.

7. The RKP seed tube guard for John Deere XP shank assemblies mount the same as original equipment. This shank is a casting and it may be necessary to file some parting line material where the guard mounts.

8. The seed tube guides (A) keep the seed tube centered.

Notes:

1. If the Keeton wrap around mounting is used we recommend you use the universal version only.

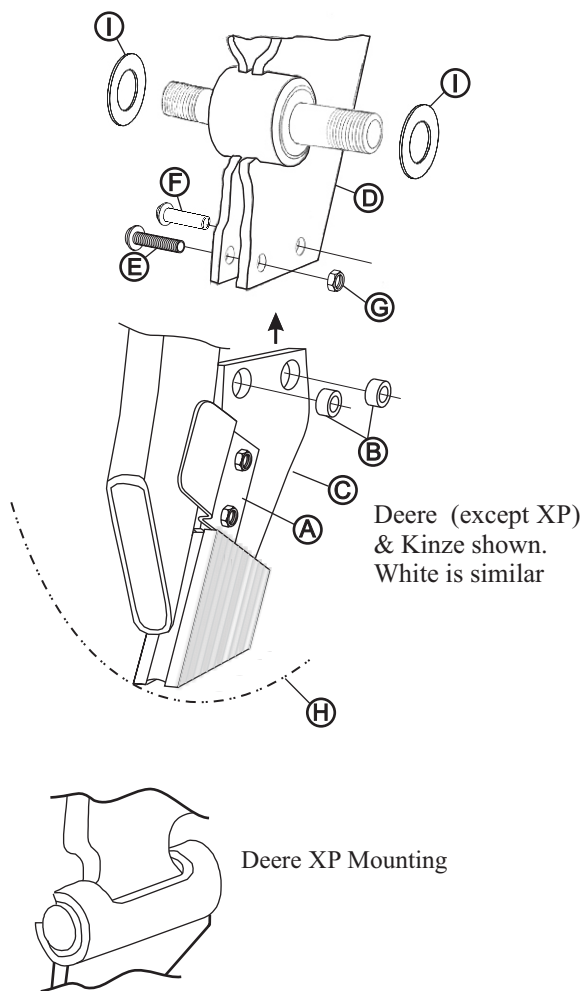

Think Safety

2. We recommend that this product not be used with opener disks that are worn to less than 14 1/2" diameter.
3. Because the wear surfaces are more durable a consistent width furrow will be maintained for a longer period of time. This should allow the seed to reach the furrow bottom more consistently. **This may require you to set the planting depth control to a shallower setting than you are accustomed to.**