

INSTRUCTIONS FOR INSTALLING CLOSING WHEEL FRAME PIVOT KITS ON JD 7200 SERIES PLANTERS WITH CARRIAGE

When working on your planter in the raised position be certain that service locks are installed or parking stands are down and properly secured. Wear proper protective clothing and eye protection. Review the safety section in your operators manual.

IMPORTANT: READ INSTRUCTIONS CAREFULLY

Note: The inside diameter of the bearing housing has been machined to provide approximately .015" clearance with the bearing outer race. This is to allow for some misalignment between the bearings. The bearing outer race will not slip in the housing because the friction between the balls and races is very low in comparison to that between the outer race and housing.

1. Remove closing wheel frame from planter. By unhooking the spring from the planter frame you can avoid disassembling the spring and handle. Grinding approximately 1/4" off the hook may make reassembly easier.
2. If the sides of the frame are distorted at the front they can be straightened as follows. Lay the frame on its back. By holding a hammer on one side of the sheet metal and hitting the other side the frame can be improved. Repeat as necessary. The two sides at the front should be approximately four inches apart and parallel.
3. Make sure that areas where bearing housing will be located are clean and smooth. Remove paint from areas to be welded.
4. From the inside insert the middle shoulder of the locator bushing (with bolt and nut) through the worn hole in the side of the closing wheel frame. Hold the bearing housing against the outside surface of the frame with the internal flange on the smallest shoulder of the locator bushing. Using the large washer and nut clamp the bearing housing to the frame after pushing the locator bushing forward against the unworn portion (A) of the hole.
5. Weld the bearing housing in two places as shown. Welds should be approximately 3/4" to 1" long.
6. Paint the bearing housings and welds to protect from corrosion.
7. Reassemble frame on to planter. Insert carriage bolts through clips (B) and (C) and install through the support casting from the inside as shown. Note that two different lengths of carriage bolts are provided. Locate as indicated. Assemble the LH (flat) clip (B) with the long end at the top. On early 7200 planters the long end will engage the top of the support casting preventing the clip and bolt from turning.
8. Later 7200 planters have a recessed area on the LH side to hold an insecticide bracket when used. In this case clip (B) should be seated into this recessed area. When insecticide brackets are used with either style casting the LH clip will not be used. Use a square file to modify the hole in the bracket to accept the carriage bolt.

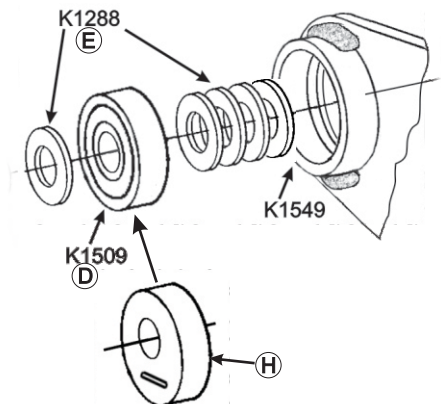
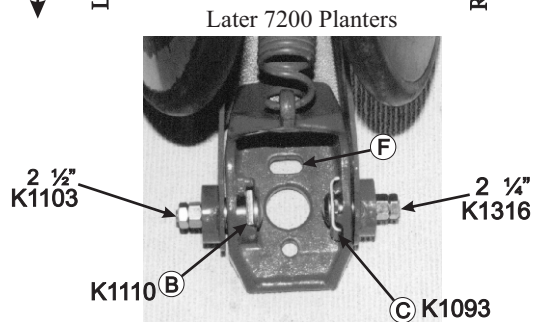
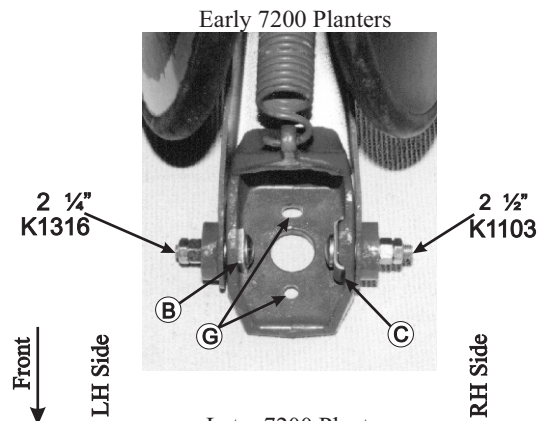
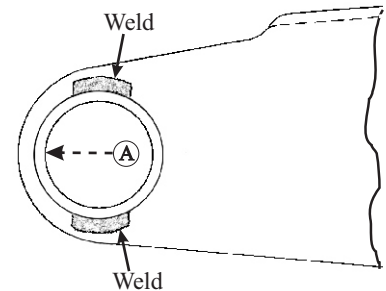

Assembly With Bearings (If Using Cams Go To Step 11)

9. Assemble the bearings (D) and flat washers (E). Install the regular nut and tighten.
10. Check the alignment of the closing wheels with the center of the row unit. The closing wheels can be adjusted by shimming them with flat washers. If additional adjustment is required on later 7200 planters a slot (F) is provided in the top of the support casting. If additional adjustment is required on earlier 7200 planters holes (G) can be slotted or oversized. Add flat washers if necessary.

The weight of the gauge wheels and arms is supported by the front of the support casting. If slot (F) and holes (G) are utilized for adjustment it may be necessary to lock the arms up or remove them while making the above adjustments.

Assembly With Cams

11. Assemble cams (H), flat washers (E) and the regular nut. Turn cams to neutral position as shown (adjustment slot at bottom). If adjustment is required to center closing wheels on the row, rotate one cam forward and the other an equal amount rearward. The right hand bolt should be at the top of the slot in the support casting to keep the closing wheel frame level.
12. Tighten the regular nuts to 85 ft-lb torque. Install the locking jam nuts and tighten. If subsequent adjustment is required loosen both bolts and adjust both cams. This will prevent either cam from being put into a bind.