

INSTRUCTIONS FOR INSTALLING THE R K P GAUGE WHEEL ARM PIVOT KIT ON IH 800/900/955/1200 SERIES PLANTERS

When working on your planter in the raised position be certain that service locks are installed or parking stands are down and properly secured. Wear proper protective clothing and eye protection. Review the safety section in you operator's manual.

IMPORTANT: READ INSTRUCTIONS CAREFULLY

Before installing this kit we recommend making other necessary repairs such as replacing opener disks, bearings and seed tube guards. Badly worn seed tube guards will allow the opener disks to flex inward away from the tires. It is not necessary to replace opener disk scrapers. Proper installation of the R K P Gauge Wheel Arm Pivot Kit will result in the opener disks being cleaned by the gauge wheel tires therefore the scrapers can usually be eliminated.

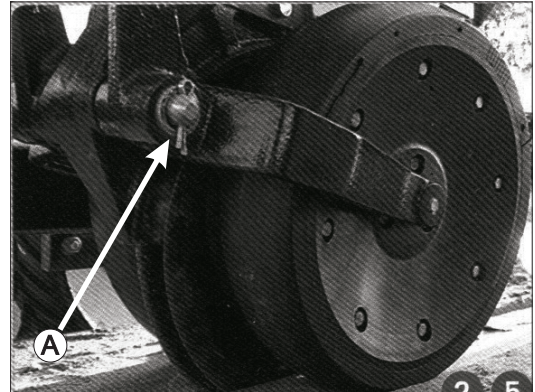

(800/900 Shown)

REMOVAL

1. Remove arm by removing cotter pin (A) and washers. If necessary, file the ends of the gauge wheel arm hub to make sure they are smooth and flat. Clean the bore. If there is a dust drain hole in the bottom of the hub close it with "J B Weld" or similar material. Welding is also an option. Remove original pivot shafts.

INSTALL PIVOT SHAFTS

2. Install a grade 8, 5/8" nut (B) onto a grade 8, 5/8" x 1-1/2" capscrew (C). Leave a small gap of approximately one thread between the nut and capscrew head. Before installing the nut, oil the bolt threads in the area that the nut will be placed. Do not oil the remaining threads. Place heat treated flat washer (D) on capscrew (C). Screw capscrew (C) into pivot shaft assembly (E) until washer (D) is held against pivot shaft. Apply Locktite 271 (Threadlocker) or equivalent to the external and internal threads as indicated. The threads must be clean and dry before application. Install pivot shaft assembly (E) into tapped hole (F). Using a socket that engages both the head of the capscrew (C) and the nut (B) torque to 175 ft-lbs. **Do not use impact wrench.**
3. With the socket engaging the capscrew head only, tighten capscrew (C) while loosening nut (B) with a 15/16" wrench. Remove capscrew with nut and washer (D). Wipe oil from end of pivot shaft (E).

INSTALL ARMS

4. **Make sure that the adjusting washers at position (G) will lay flat on inner end of hub. If the arm interferes eliminate the interference by grinding.** Sixteen adjusting washers K1019 are provided for each arm. Place approximately five adjusting washers (G) onto pivot shaft (E). This is an approximate number and should result in a small gap between the tire and opener disk in **step 7**. More adjusting washers will be moved to position (G) if necessary. Install gauge wheel arm with wheel (not shown). Place enough adjust adjusting washers (I) outside of arm until they are approximately flush with end of pivot shaft. Lightly lubricate washers during assembly in this or subsequent steps.
5. Install locknut (J) flush with outer end of adjusting stud (K). Install disc spring (L), tab washer (M), the adjusting washers (N) and washer K1600 onto the adjusting stud assembly (K). Screw adjusting stud assembly into tapped hole in pivot shaft (E) and tighten. A special extension K1610 is required to clear the grease zerk.

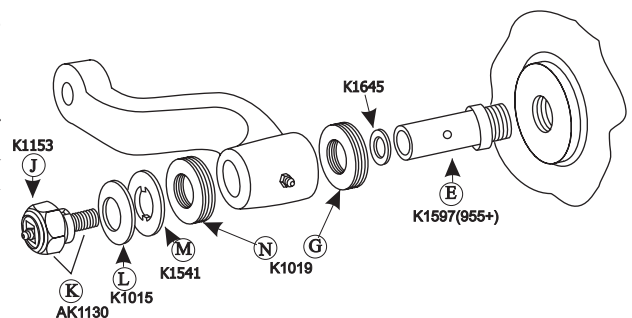
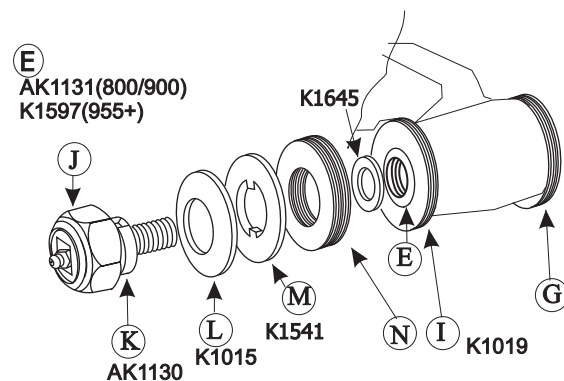
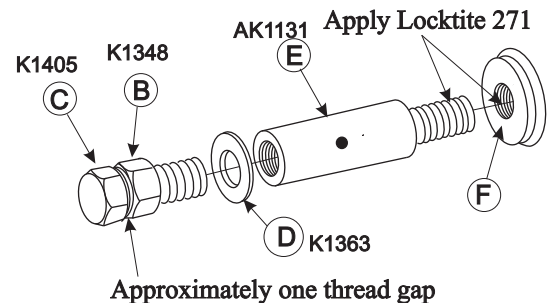

6. Tighten locknut (J) until the arm and wheel assembly stays up under its own weight. **For installation purposes** there should initially be a gap between the tire and disk. If necessary move some adjusting washers (N) to position (G). This gap will be eliminated in step 8. Occasionally it may be necessary to move the hub of the arm out onto the adjusting stud.

With the arm in an average operating position, turn the tire and determine where the gap between the tire and disk is smallest. Using adjusting washers as a feeler gauge determine how many adjusting washers (G) inside of hub need to be moved to position (I) outside of hub to allow the tire to rub the opener disk with light to moderate pressure. Do not move washers until step 8.

The purpose of locknut (J) is to set the disc spring pressure on the hub of the arm. It does not have anything to do with determining the relationship of the tire to the opener disk. That is determined entirely by the number of adjusting washers at position (G).

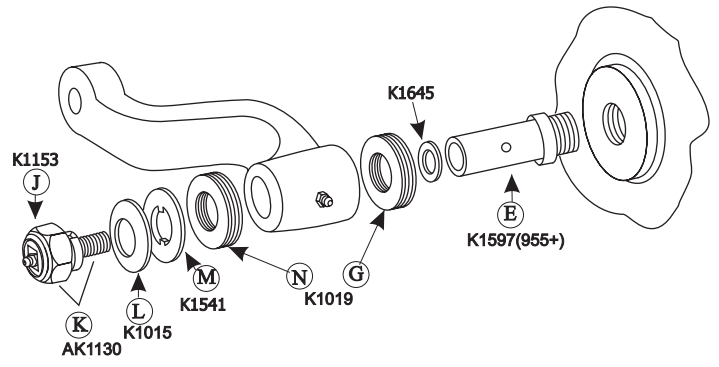

7. Loosen locknut (J) so wheel comes down. Retighten locknut (J) until a slight resistance is felt when raising and lowering the wheel by hand. The arm may tend to “hang up” slightly. At this point disc spring pressure will result in approximately 1500 lbs preload on the hub of the arm.
8. Remove the gauge wheel arm by removing adjusting stud assembly (K). Do not remove the locknut, disc spring, tab washer and adjusting washers from the adjusting stud. Move correct number of adjusting washers from position (G) to position (I) as determined in step 6. Reinstall the adjusting stud with disc spring and washers. Tighten adjusting stud to 105ft lbs torque. **Do not use impact wrench.**
9. Grease the pivot joint. We recommend that you lubricate daily. Longer intervals are probably very acceptable however. You will have to determine the correct interval for your conditions.
10. After several days operation check the disc spring pressure. Check the disc spring pressure at least once a year thereafter. **If looseness is detected make sure the adjusting stud is seated against the pivot shaft and torqued to 105 ft lbs before tightening the locknut. It may be necessary to back the nut off to be sure that the adjusting stud is seated against the pivot shaft.**

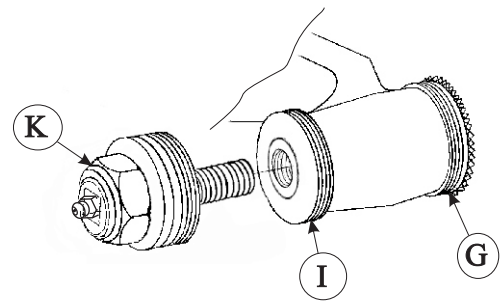
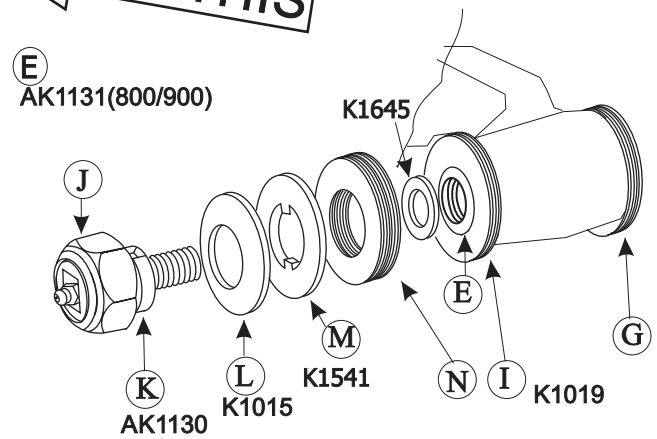

Special Notes:

1. Locknut (K) size is 1 7/16" across flats. Many 12" adjustable wrenches will open to 1 7/16" but yours may not. If not, it is a simple matter to remove the required material from the stationary jaw of the wrench using a bench grinder.
2. In most cases the gauge wheel tire will rub the opener disk at the ground line (or at least have a very small gap) without excessive pressure between the tire and disk at some other point. If this is accomplished, moist dirt will be cleaned from the opener disk as the disk emerges from the ground. In this case the disk scrapers serve no purpose and can be removed.
3. Occasionally, due to damaged parts or manufacturing variation, you may have a gap of 1/16" or more between the opener disk and the tire at the ground line. Generally this will cause no problem but you should consider the following: