

INSTRUCTIONS FOR INSTALLING THE R K P GAUGE WHEEL ARM PIVOT KIT ON JOHN DEERE 1700 SERIES PLANTERS

When working on your planter in the raised position be certain that service locks are installed or parking stands are down and properly secured. Wear proper protective clothing and eye protection. Review the safety section in you operator's manual.

IMPORTANT: READ INSTRUCTIONS CAREFULLY

Before installing this kit we recommend making other necessary repairs such as replacing opener disks, bearings and seed tube guards. Badly worn seed tube guards will allow the opener disks to flex inward away from the tires. It is not necessary to replace opener disk scrapers. Proper installation of the R K P Gauge Wheel Arm Pivot Kit will result in the opener disks being cleaned by the gauge wheel tires therefore the scrapers can usually be eliminated.

REMOVAL

1. Remove arms by removing bolt (A). Remove threaded bushing from hub of arm. If necessary file the ends of the gauge wheel arm hub to make sure they are smooth and flat. Clean the bore.

INSTALL PIVOT SHAFTS

2. Install a grade 8, 5/8" nut (B) onto a grade 8, 5/8"x 1-1/2" capscrew (C). Leave a small gap of approximately one thread between the nut and capscrew head. Before installing the nut, oil the bolt threads in the area that the nut will be placed. Do not oil the remaining threads. Place heat treated flat washer (BB) on capscrew (C). Screw capscrew (C) into pivot shaft assembly (D) until washer (BB) is held against pivot shaft. Apply Loctite 271 (Threadlocker) or equivalent to the external and internal threads as indicated. The threads must be clean and dry before application. Install pivot shaft assembly (D) into tapped hole (E). Using a socket that engages both the head of the capscrew (C) and the nut (B) torque to 175 ft-lbs. **Do not use impact wrench.**
3. With the socket engaging the capscrew head only, tighten capscrew (C) while loosening nut (B) with a 15/16" wrench. Remove capscrew with nut and washer (BB). Wipe oil from end of pivot shaft (D).

INSTALL ARMS

4. Press split bushing (F) into bore of arm (G). The easy way to do this is to lay the wheel on the floor. Place a block under the hub of the arm. Squeeze the bushing with pliers. Place the split approximately in line with the grease zerk and tap into place. If the bushing is loose widen the split with a screw driver.
5. **Make sure that the adjusting washers at position (H) will lay flat on inner end of hub. If the arm interferes eliminate the interference by grinding.** Sixteen adjusting washers K1019 are provided for each arm. Place approximately five adjusting washers (H) onto pivot shaft (D). This is an approximate number and should result in a small gap between the tire and opener disk in **step 7**. More adjusting washers will be moved to position (H) if necessary. Install gauge wheel arm with wheel (not shown). Place enough adjusting washers (I) outside of arm until they are approximately flush with end of pivot shaft. Lightly lubricate washers during assembly in this or subsequent steps.
6. Install locknut (J) flush with outer end of adjusting stud (K). Install disc spring (L), tab washer (M), the remaining adjusting washers (N) and washer K1600A onto the adjusting stud assembly (K). Screw adjusting stud assembly into tapped hole in pivot shaft (D) and tighten.

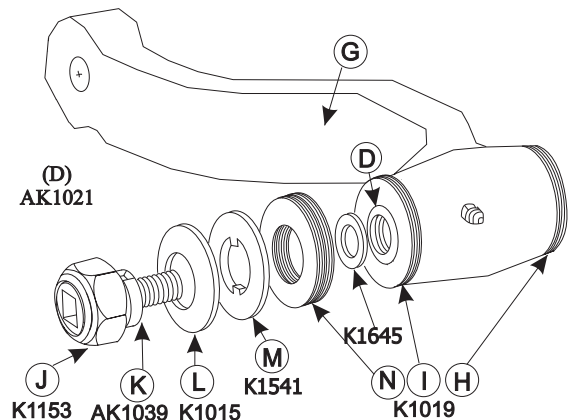
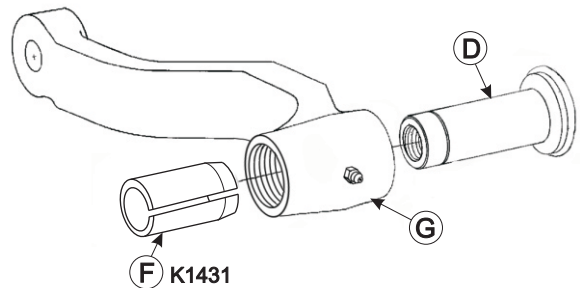
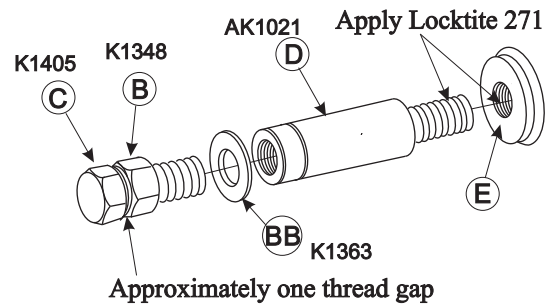
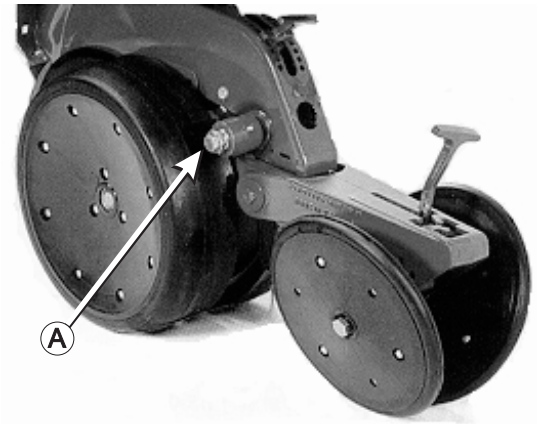

7. Tighten locknut (J) until the arm and wheel assembly stays up under its own weight. **For installation purposes** there should initially be a gap between the tire and disk. If necessary move adjusting washers to position (H). This gap will be eliminated in step 9. Occasionally it may be necessary to move the hub of the arm onto the adjusting stud.

With the arm in an average operating position, turn the tire and determine where the gap between the tire and disk is smallest. Using adjusting washers as a feeler gauge determine how many adjusting washers (H) inside of hub need to be moved to position (I) outside of hub to allow the tire to rub the opener disk with light to moderate pressure. Do not move washers until step 9.

The purpose of locknut (J) is to set the disc spring pressure on the hub of the arm. It does not have anything to do with determining the relationship of the tire to the opener disk. That is determined entirely by the number of adjusting washers at position (H).

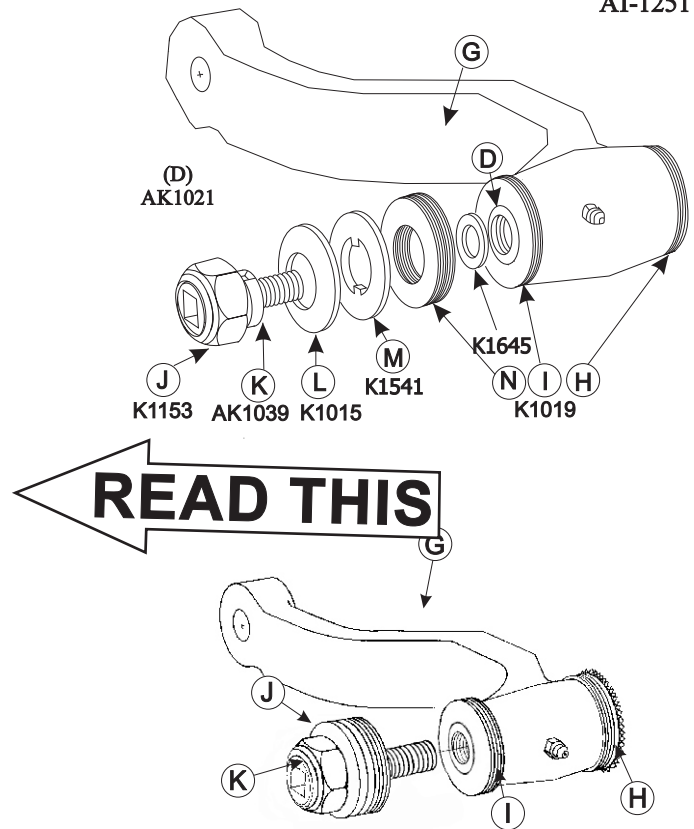

8. Loosen locknut (J) so wheel comes down. Set disc spring pressure as indicated below:
- If your planter is equipped with the "Walking Gauge Wheel" attachment set disc spring pressure as follows. Tighten locknut (J) until a slight resistance is felt when raising and lowering the wheel by hand. The arm may tend to "hang up" slightly. At this point disc spring pressure will result in approximately 1500 lbs preload on the hub of the arm.
 - If planter has no "Walking Gauge Wheel" attachment we recommend that the disc spring pressure be set high enough that the arms stay up against the adjustable stop but can still be pushed down with moderate force (approximately 20-25 lbs).
9. Remove the gauge wheel arm by removing adjusting stud assembly (K). Do not remove the locknut, disc spring, tab washer and adjusting washers from the adjusting stud. Move correct number of adjusting washers from position (H) to position (I) as determined in step 7. Reinstall the adjusting stud with disc spring and washers. Tighten adjusting stud to 105ft lbs torque. **Do not use impact wrench.**
10. Grease the pivot joint. If you set the disc spring pressure as in step 8 (a) we recommend that you lubricate daily. Longer intervals are

- probably very acceptable however. You will have to determine the correct interval for your conditions. If you set disc spring pressure as in step 8(b) annual lubrication is sufficient.
11. After several days operation check the disc spring pressure. Check the disc spring pressure at least once a year thereafter. **If looseness is detected make sure the adjusting stud is seated against the pivot shaft and torqued to 105 ft lbs before tightening the locknut. It may be necessary to back the nut off to be sure that the adjusting stud is seated against the pivot shaft.** Set disc spring pressure as in step 8. Check tightness of adjusting stud (K) whenever locknut (J) has been turned counter clockwise.

Special Notes:

- Locknut (J) size is 1 7/16" across flats. Many 12" adjustable wrenches will open to 1 7/16" but yours may not. If not, it is a simple matter to remove the required material from the stationary jaw of the wrench using a bench grinder.
- In most cases the gauge wheel tire will rub the opener disk at the ground line (or at least have a very small gap) without excessive pressure between the tire and disk at some other point. If this is accomplished, moist dirt will be cleaned from the opener disk as the disk emerges from the ground. In this case the disk scrapers serve no purpose and can be removed.
- Occasionally, due to damaged parts or manufacturing variation,

you may have a gap of 1/16" or more between the opener disk and the tire at the ground line. Generally this will cause no problem but you should consider the following:

- The gap between the opener disk and the tire can sometimes be reduced by moving arms to the opposite side of the row unit or by exchanging arms between row units. If the arms are left hand and right hand they cannot be moved to the opposite side of the row unit.
- Arms can also be heated and twisted or bent to bring the tire closer to the opener disk.